

CARACTERÍSTICAS

- Modo doble velocidad de elevación.
- Alimentación trifásica de 380v.
- Largo de cadena modificable.
- Clase de trabajo M5.



*Imagen referencial

TECLE ELECTRICO AMH	AMH0.5-01S	AMS01-01S	AMS01-02S	AMS02-02S
CAPACIDAD (kg)	500	1.000	1.000	2.000
VELOCIDAD DE ELEVACION (m/min)	8/2	8/2	4/1	4/1
POTENCIA DEL MOTOR DE ELEVACION (kw)	0.8/0.2	1.6/0.4	0.8/0.2	1.6/0.4
FUENTE DE ALIMENTACION (v)	380v			
Nº CADENAS	1	1	2	2
ESPECIFICACIONES DE CADENA	Ø5	Ø7.1	Ø5	Ø7.1
CONTROL DE VOLTAJE	48v			

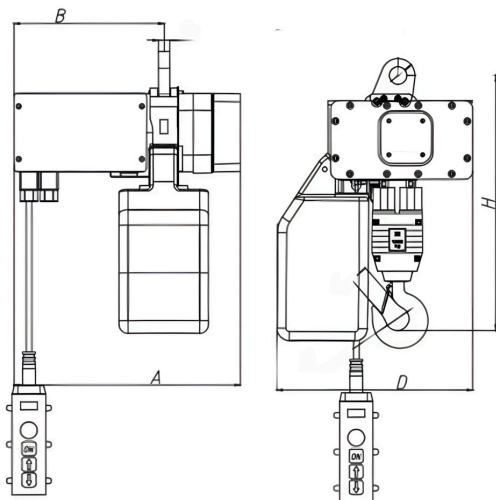

DIMENSION (mm)	AMH0.5-01S	AMS01-01S	AMS01-02S	AMS02-02S
	A	400	500	400
B	267	316	267	316
D	350	397	350	397
H	420	490	485	570